



Tabletop convenience in a rugged vial labeler.



***Setting Global Standards***  
*One Customer at a Time*

[www.ctmlabelingsystems.com](http://www.ctmlabelingsystems.com)  
[www.mpilabels.com](http://www.mpilabels.com)

# Tabletop Wrap Labeler

## Features:

Round products are manually loaded onto the infeed magazine. The indexing starwheel will remove one product at a time from the infeed magazine with each indexing motion. Once products have been captured by the starwheel, they are indexed to the labeling station where a powered roller spins the product as the label is applied. Labeled products will then continue around the starwheel until they fall onto the exit chute where they will fall into a collection hopper (collection hopper or box is not included.)

## Standard Features:

Completely enclosed, rugged, anodized aluminum construction. Microprocessor controlled.

(1) Custom set of machined starwheels included.

Adjustable infeed magazine accommodates a wide variety of cylindrical products.

## Options:

Additional Starwheels.

Hot stamp imprinters.

Loose loop integration with thermal printers.

Clear label sensing.

16" Diameter label roll capacity.

## Electrical:

120 Volts AC, 7 Amps

50/60 Hertz

## Pneumatic:

80 PSI, 2 CFM

## Speed:

225-330 IPM  
Up to 50 PPM - Depends  
on product and label sizes.

## Roll Capacity:

12" OD, 3" ID  
(optional 16" OD, 3" ID available)

## Product Dimensions:

Max Dia.: 2.500"  
Min Dia.: .313"  
Max Length: 6.000"  
Min Length: .750"

## Label Dimensions:

Max Width: 5.000"  
Min Width: .500"  
Max Length: 8.000"  
Min Length: .500"

## Label Sensing:

Photoelectric

## Dimensions:

40" H, 48" W, 25" D

## Weight:

250 lbs.

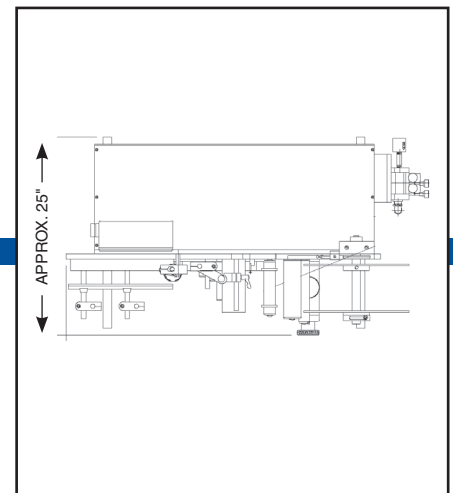
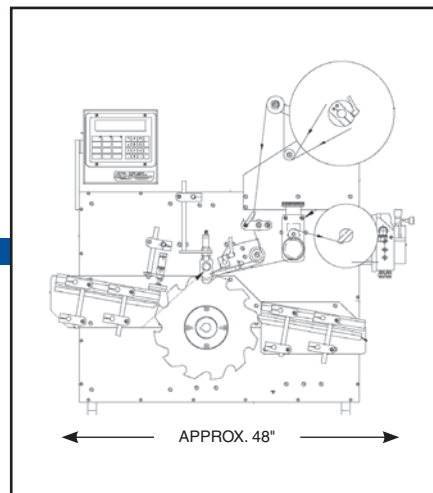
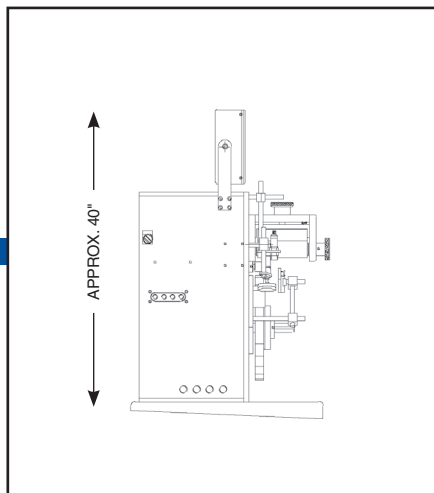

Distributed By:



1421 W. Main Street  
Alliance, Ohio 44601  
330-938-2134

[www.mpilabels.com](http://www.mpilabels.com)



1318 Quaker Circle  
P.O. Box 589  
Salem, Ohio 44460  
(330) 332-1800



[www.ctmlabelingsystems.com](http://www.ctmlabelingsystems.com)