

# Model 3139/38-N



Featuring patented vacuumized drum



3139/38-N

Printer Applicator

Have a Label-Aire Authorized Distributor contact you. Visit [www.mpilabels.com](http://www.mpilabels.com).



# 3139/38-N Printer Applicator Specifications

The Label-Aire® Model 3139/38-N Printer Applicator makes print and apply labeling even easier.

The Model 3139/38-N Printer Applicator thermal transfer or direct transfer imprints and applies labels around any corner or two labels on adjacent panels utilizing a vacuumized drum.

The Model 3138-N with its built-in label unwind and rewind capabilities is utilized for one-to-one print and apply allowing for the immediate application of each label as it is printed. The 3139/38-N's sturdy swing arm can be configured for cartons or pallets. The heavy duty square-frame mounting stand can be bolted to the floor for added stability. The 3139/38-N is compatible with most O.E.M. printers.

Put this advanced workhorse printer applicator to work for you. The Model 3139/38-N Printer Applicator is designed to run seamlessly in your operation, saving you money in the long run.

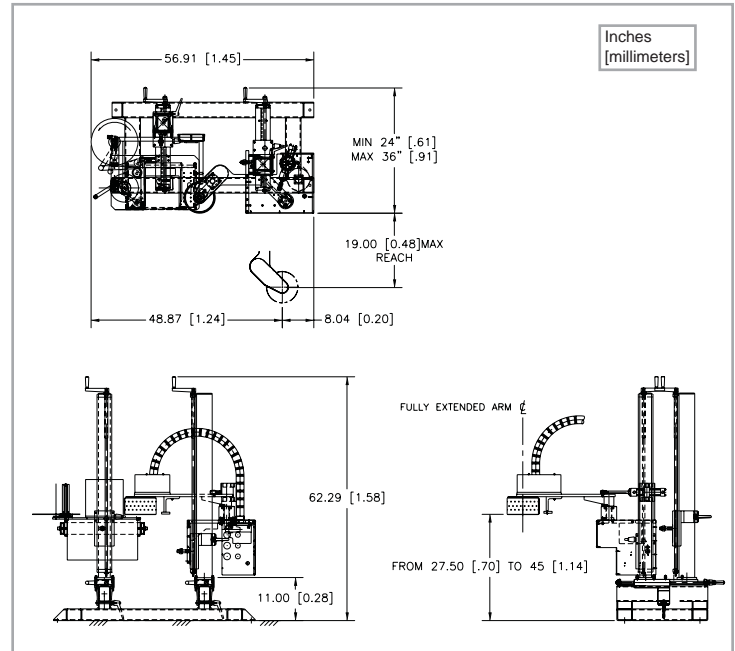

3139/38-N Advanced Features	
<b>Automatic setup</b>	Includes multiple programmable label pages for easy change-overs to different label sizes.
<b>Digital display</b>	Remote operator control capability.
<b>Flash memory</b>	Allows easy download of system software updates.
<b>Advanced I/O</b>	User-configurable for system output.
<b>Heavy duty air cylinder</b>	For heavy duty label application.
<b>Stepper rewind</b>	Comes standard for waste take up.

### Dimensions:

Height: 62.29" (1.58 m)  
 Length: 56.91" (1.45 m)  
 Width: 24" (.61 m) Min. (Max. width dependent upon arm length.)

### Weight:

Approx. 500 lbs. (227 kg)

### Standard Label Dimensions:

Label Width: Up to 7" (177.8 mm)  
 Label Length: Up to 24" (610 mm)  
*(Printer dependent)*

### Dispense Speed:

Up to 16" (406 mm) per second depending on printer and label size

### Label Placement Accuracy:

Up to +/- 1/8" (.125 mm)

### Electrical:

115 Volts AC 60 Hz 5 Amps.  
 220 Volts AC 50 Hz

### Air (as needed):

4 cfm at 90 psi for most applications

### Options:

Most O.E.M. print engines  
 Wide range of arm lengths  
 RFID configurable  
**Consult factory for additional options.**



### Headquarters

550 Burning Tree Road  
 Fullerton, CA 92833 USA

o 714.441.0700  
 f 714.526.0300  
 e info@label-aire.com  
 w www.label-aire.com

### Europe

Sjællandsvej 27A  
 DK-9500 Hobro, Denmark

o +45.9657.0063  
 f +45.9657.0064  
 e info@label-aire.com  
 w www.label-aire.com

### Asia

No. 10, Lane 228, Taisi S. Road  
 Longjing Township  
 Taichung County 434, Taiwan

o +886.4.2395.5684  
 f +886.4.2395.8007  
 e info@label-aire.com

Distributed by:

