

Model 314-NV

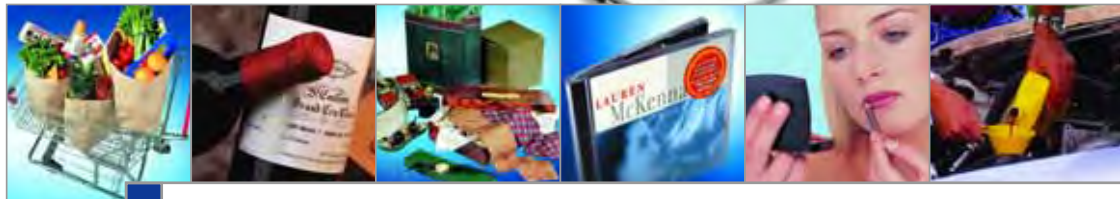

3114-NV Tamp-Blow

Primary Applicator

The NEW Label-Aire® Model 3114-NV makes labeling easier and faster...making you more profitable.

The Model 3114-NV Tamp-Blow labeler delivers on its promise of speed, accuracy, and ease of use. And that translates into lower operating costs and increased productivity for your business.

The Label-Aire Model 3114-NV was designed for high-speed tamp-blow labeling applications at a standard dispense speed of up to 1,500" (38.1 m) of web per minute or up to 2,000" (50.8 m) with the optional powered rewind. Advanced features include Velocity Compensation for improved label placement accuracy, a microprocessor controller with digital display, and ambidextrous parts. Zero Downtime Labeling allows your production to continue without costly interruptions. Missing label compensation virtually eliminates unlabeled products. Furthermore, the 3114-NV comes standard with a heavy duty double stack stepper motor—at no extra charge as well as a standard 1" to 10" (25.4 mm to 254 mm) adjustable stroke. Not only can the 3114-NV be easily converted to left- or right-hand use, it can also apply labels to the top, side, or bottom of products with a label dispense accuracy of up to +/- 1/32" (.8 mm). Adding to the 3114-NV's versatility are the availability of air-blow and wipe-on conversion kits.

Put this tamp-blow pressure-sensitive technology to work for you all day, every day. The Model 3114 Tamp-Blow labeler is built to meticulous quality standards and designed to withstand the most demanding operation.

Have a Label-Aire Authorized Distributor contact you. Visit www.mpilabels.com.



3114-NV Tamp-Blow Specifications

Dimensions:

Height: 29.6" (684.9 mm)
 Length: 34.72" (881.9 mm)
 Width: 25.08" (637.1 mm)

Weight:

140 lbs. (63.5 kg)

Standard Label Dimensions:

Max. Web Width: 7.13" (181 mm)
 Optional 7.13" (181 mm) web width
 Min. Web Width: .63" (16 mm)
 Min. Label Length: .75" (19 mm)

Label Packaging:

16" (406 mm) O.D. rolls std. on
 3" (76 mm) I.D. cores
 20" (508 mm) powered rewind and
 powered unwind

Dispense Speed:

Up to 1,500" (38.1 m) of web per
 minute (standard)
 Up to 2,000" (50.8 m) of web per
 minute with smart powered rewind

Label Dispense Accuracy:

+/- 1/32" (.8 mm)

Electrical:

115 Volts AC 60 Hz 3 Amps.
 220 Volts AC 50 Hz optional

Air:

4 cfm at 90 psi to 110 psi for
 most applications

Options:

Smart 10" (254 mm) powered rewind
 Smart 20" (508 mm) powered unwind
 and powered rewind
 6" (152 mm) label core adapter
 Encoder kit for Velocity Compensation
 Strobe signals for "low label" and
 "out of labels"
 Clear label sensor upgrade
 Hot stamp imprinter
 Display tilt mounting brackets
 Model 2700 T-Base stand

Consult factory for additional options.

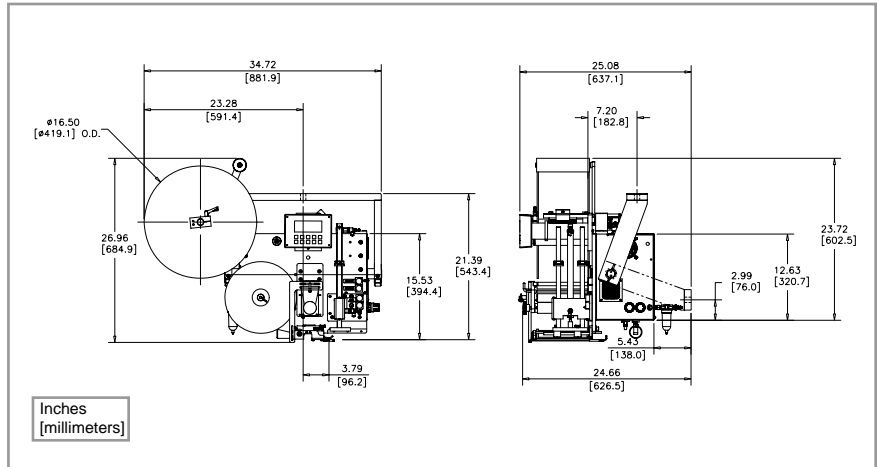

Stated dimensions are approximations. Please consult factory if dimensions are required for line integration.

3114-NV Tamp-Blow

Advanced Features

Automatic setup	Includes multiple programmable label pages for easy changeovers to different label sizes.
Standard adjustable stroke	1" to 10" (25.4 mm to 254 mm)
Stepper motor drive	For precise starting/stopping, increased reliability, wider range speed variability, and lower maintenance.
R3 digital display	Select from five languages (English, French, German, Italian, Spanish), domestic or CE (European) configurations, standard/metric unit display and detailed alarm messages. Can rotate 360° in 90° increments.
Velocity Compensation	For improved label placement accuracy.
Optional quick-action collapsible rewind	Allows easy removal of scrap liner.
Optional smart powered rewind	For dynamic web tension control.
Tamp-blow applicator	Easily adapts to air-blow or wipe-on use.



Headquarters

550 Burning Tree Road
 Fullerton, CA 92833 USA

o 714.449.5155
 f 714.526.0300
 e info@label-aire.com
 w www.label-aire.com

Europe

Sjællandsvej 27A
 DK-9500 Hobro, Denmark

o +45.9657.0063
 f +45.9657.0064
 e info@label-aire.com
 w www.label-aire.com

Asia

No. 10, Lane 228, Taisi S. Road
 Longjing Township
 Taichung County 434, Taiwan

o +886.4.2395.5684
 f +886.4.2395.8007
 e info@label-aire.com
 w www.label-aire.com

Distributed by:



1421 W. Main Street
 Alliance, Ohio 44601
 330-938-2134
www.mpilabels.com