

Model 3015-ND



3015-ND Wipe-On

Primary Applicator

The Label-Aire® Model 3015-ND Wipe-On Primary Applicator is an affordable wipe-on labeler that's easy to use and even easier on your bottom line.

The Model 3015-ND Wipe-On labeler delivers on its promise of speed, accuracy, ease of use, and affordability. The results are lower operating costs and increased productivity for your business.

The Label-Aire Model 3015-ND was designed for simple wipe-on labeling applications in all markets (available in either 220 Volts, 50 Hz or 115 Volts, 60 Hz configurations). Underneath the 3015-ND is an advanced labeler that comes with many standard features making it an exceptional value. Not only can the 3015-ND be easily converted to left- or right-hand use, it can also apply labels to the top, side, or bottom of products at a dispense speed of up to 1,000" (25 m) of web per minute with a label dispense accuracy of up to +/- 1/32" (.8 mm).

Put this affordable wipe-on pressure-sensitive technology to work for you all day, every day. Like every machine we make, the Model 3015-ND Wipe-On is built to Label-Aire's meticulous quality standards.

Have a Label-Aire Authorized Distributor contact you. Visit www.mpilabels.com.



3015-ND Wipe-On Specifications

Dimensions:

Height: 26.22" (666 mm)
 Length: 27.66" (702 mm)
 Width: 15.9" (404 mm)

Weight:

80 lbs. (36.3 kg)

Standard Label Dimensions:

Max. Web Width: 6" (152.4 mm)
 Min. Web Width: .63" (16 mm)
 Min. Label Length: .375" (9.5 mm)
 Max. Label Length: 20" (508 mm)

Label Packaging:

12" (305 mm) O.D. rolls std. on
 3" (76 mm) I.D. cores

Dispense Speed:

Up to 1,000" (25 m) of web per minute

Label Dispense Accuracy:

Up to +/- 1/32" (.8 mm)

Electrical:

115 Volts AC 60 Hz 2.5 Amps. or
 220 Volts AC 50 Hz 5 Amps.

Air (as needed):

2 cfm at 60 psi to 90 psi when imprinter
 is used

Options:

6" (152 mm) label core adapter
 Encoder kit for Automatic Speed Following
 3-color light Stack for "Ready", "Warning",
 and "Fault"
 Clear label sensor upgrade

Consult factory for additional options.

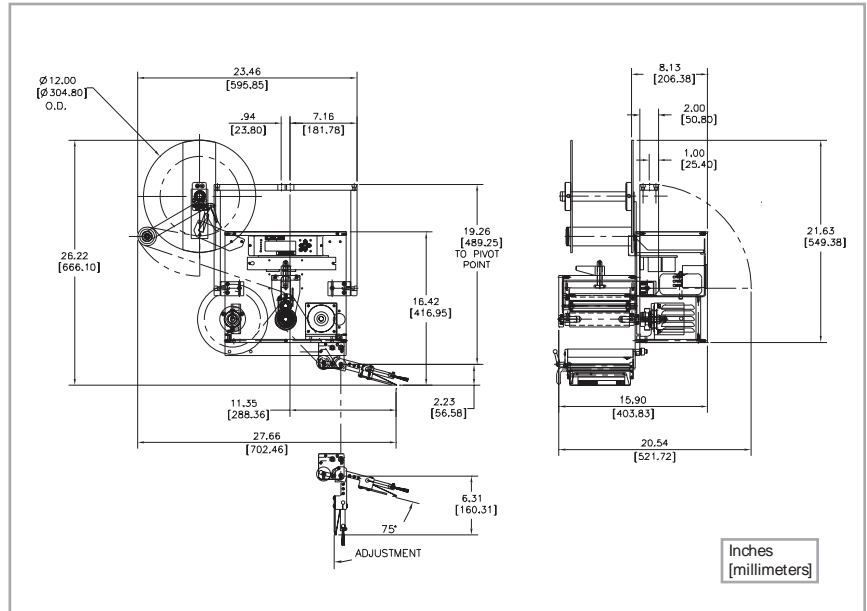

Stated dimensions are approximations. Please consult factory if dimensions are required for line integration.

3015-ND Wipe-On Advanced Features

User-friendly control panel	Multi-functional and easy to use to reduce set up time.
Stepper motor drive	For precise starting / stopping, increased reliability, wider range speed variability, and lower maintenance.
Microprocessor controlled	Repeatable settings and constant monitoring ensures reliable operation.
Automatic Speed Following (ASF)	Labels are accurately applied even through extreme changes in product line speed.
6" (152.4 mm) configuration	To handle a wide range of label sizes.
Added versatility	Applies labels to the top, side, or bottom of products.
Wipe-on applicator	Label dispense accuracy up to $\pm 1/32"$ (.8 mm).
Configuration	Easy conversion to left - or right-hand use.



Headquarters

550 Burning Tree Road
 Fullerton, CA 92833 USA

o 714.449.5155
 f 714.526.0300
 e info@label-aire.com
 w www.label-aire.com

Europe

Sjællandsvej 27A
 DK-9500 Hobro, Denmark

o +45.9657.0063
 f +45.9657.0064
 e info@label-aire.com
 w www.label-aire.com

Asia

No. 10, Lane 228, Taisi S. Road
 Longjing Township
 Taichung County 434, Taiwan

o +886.4.2395.5684
 f +886.4.2395.8007
 e info@label-aire.com
 w www.label-aire.com

Distributed by:



1421 W. Main Street
 Alliance, Ohio 44601
 330-938-2134
 www.mpilabels.com