



H Base stands are available in carbon steel or stainless steel options. Patented internal assembly designed for ease of vertical height adjustment.



***Setting Global Standards***  
*One Customer at a Time*

[www.ctmlabelingsystems.com](http://www.ctmlabelingsystems.com)  
[www.mpilabels.com](http://www.mpilabels.com)

# H Base Stands

## Features:

Heavy duty one-piece base construction of welded carbon steel tubing or stainless steel option.

Vertical upright construction of .250" wall DOM Steel tubing.

Patented internal assembly designed for ease of vertical height adjustment.

Traverse construction of Thomson bearings and rails.

Traverse assemblies are equipped with a "half nut" feature allowing both "quick positioning" and "fine adjustment."

All carbon steel components are coated with a rust inhibitive primer and finished with **"Steel It"** polyurethane paint.

All aluminum parts are anodized.

Stands are supported on 4" diameter locking casters (leveling pads are optional.)

## Options:

- ~~Low~~ **Low** profile base enable the stand to nest under forms feed tables or other product conveyors with space restrictions.
- ~~X~~ **X** & ~~Y~~ **Y** axis traverse slide for optimum adjustment capability
- ~~Stainless~~ **Stainless** components
- ~~air~~ **air** yard
- ~~lift~~ **lift**
- ~~Leveling~~ **Leveling**
- ~~Extended~~ **Extended** height
- ~~Extended~~ **Extended** width
- ~~Drop-down~~ **Drop-down** plate
- ~~Control~~ **Control**
- **Customizing** stands

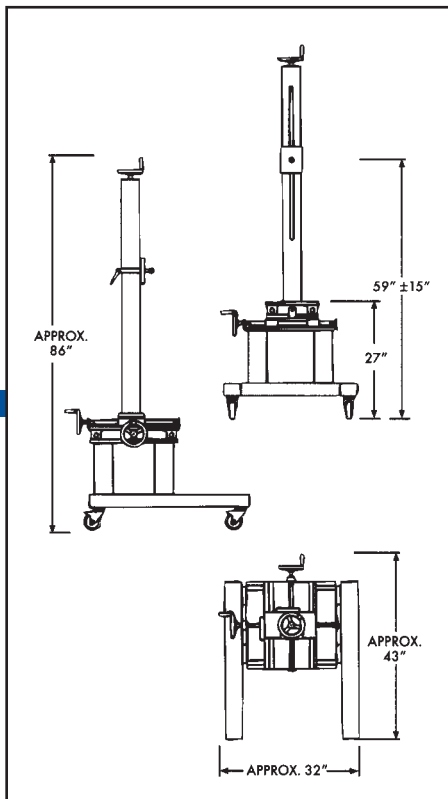

Double Traverse H-Base

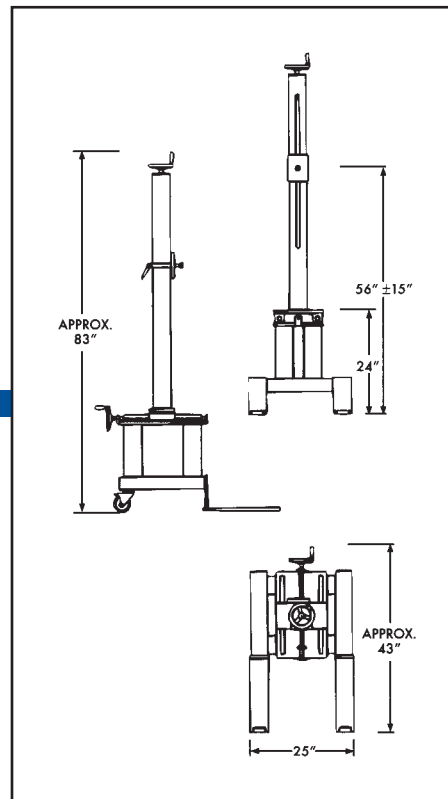

Low-Profile H-Base

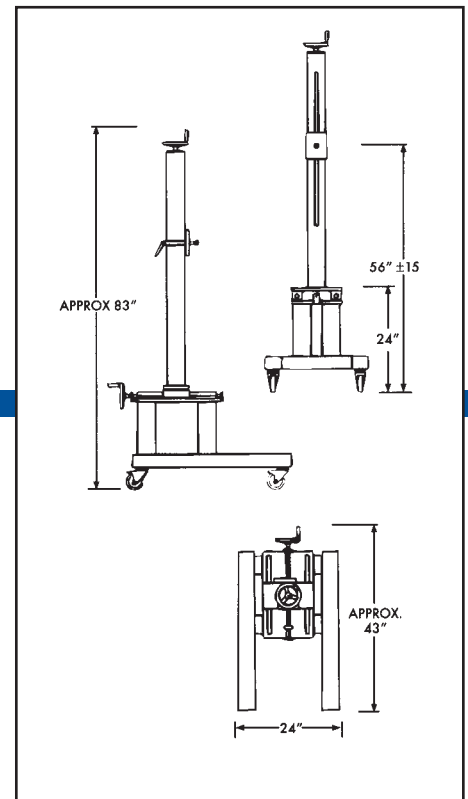

Single H-Base

Distributed By:



1421 W. Main Street  
Alliance, Ohio 44601  
330-938-2134

[www.mpilabels.com](http://www.mpilabels.com)



1318 Quaker Circle  
P.O. Box 589  
Salem, Ohio 44460  
(330) 332-1800



[www.ctmlabelingsystems.com](http://www.ctmlabelingsystems.com)