



The 360a FFS Series Label Applicator is the most versatile, high performance industrial duty labeler on the market today.



*Setting Global Standards*  
*One Customer at a Time*

[www.ctmlabelingsystems.com](http://www.ctmlabelingsystems.com)  
[www.mpilabels.com](http://www.mpilabels.com)

# The 360a FFS Form, Fill and Seal Labeler

## Features:

The 360a FFS Series Label Applicator is the most versatile, high performance industrial duty labeler on the market today. The 360 Series Label Applicator has understandably become the benchmark of labelers in its class due to its rugged and versatile design and standard features that are optional on most competitive machines. This labeler is now available in a form fill and seal (FFS) version. The new 360a FFS is designed for most form, fill and seal applications along with those applications that allow for a limited amount of space for the labeler. Application needs change? No problem, the 360a FFS has an adjustable snorkel that adjusts the applicator's labeling point from 18" to 30". Just one more example of the versatility of the CTM 360 Series workhorse line.

## CTM 360FFS Highlights:

- Engineered to minimize the overall applicator size for those "tough to reach" labeling applications.
- Adjustable length from 18" to 30" to encompass a wide range of labeling applications.
- Stepper motor will dispense up to 1500 inches per minute of dispense speed.
- "Touch" label set-up for label length, label stop and label sensor sensitivity.
- Labeler in-uterate indicator.
- Totalizing counter for data management.

## Electrical:

108-132 VAC, 50/60 Hertz, Single Phase, 10 amps.

## Air Consumption:

Up to 4 CFM at 60-90 psi.

## Labeling Speeds:

Programmable to 1500 inches per minute, in excess of 100 labels per minute depending upon size.

## Product Sensing:

Retroreflective scanner provided as standard; plc signal from form, fill and seal unit may be used; custom inputs available.

## Label Roll Size:

Maximum 12" OD x 3" ID core

Optional 16" OD or 20" OD x 3" or 6" ID cores

## Label Placement:

+/- 1/32"

## Dimensions:

22-1/2" Tall x 27-1/2" Deep x 35-1/4" to 47-1/4" Adjustable Length

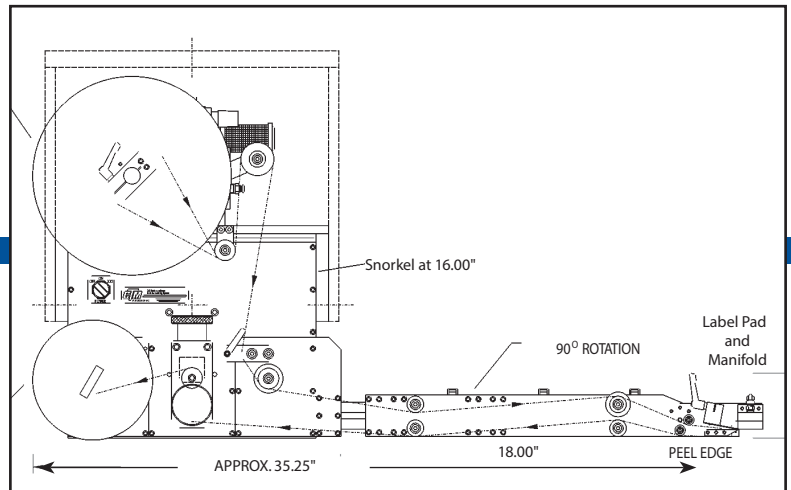
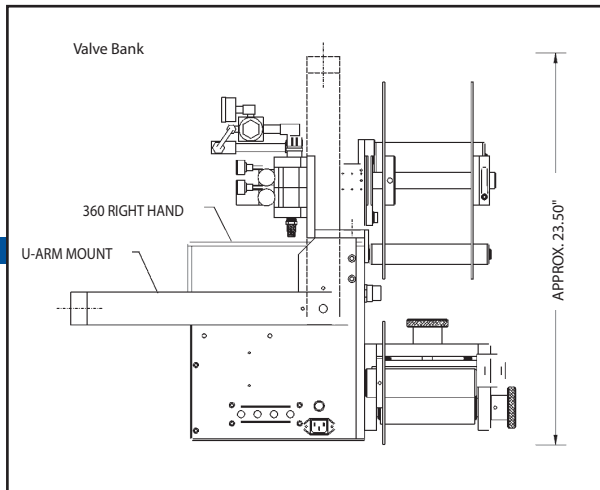

Distributed By:



1421 W. Main Street  
Alliance, Ohio 44601  
330-938-2134

[www.mpilabels.com](http://www.mpilabels.com)



1318 Quaker Circle  
P.O. Box 589  
Salem, Ohio 44460  
(330) 332-1800

