

3600ST



The 3600ST Servo Tamp Printer Applicator is a rugged and versatile high speed, thermal transfer labeler



All Electric Version Available

Setting Global Standards
One Customer at a Time

www.ctmlabelingsystems.com
www.mpilabels.com

Features

The 3600ST Servo Tamp Printer Applicator is a rugged and versatile high speed, thermal transfer labeler used to print and apply pressure sensitive labels to various products. A Sato, Zebra or Datamax print engine is integrated into an applicator to form a self-contained unit to print variable data.

Assembled with right or left hand Sato, Zebra or Datamax printer modules, the unit can be mounted in various positions to apply labels to the tops or sides of a multitude of products.

Small and large labels up to 7.1" wide can be accommodated with its built-in bar codes and alpha-numeric fonts and 203, 305 or 600 dpi print resolution.

Various onboard I/O signals are pre-wired to an external connector; optional features may be added in the field with minimum investment.

Label Size Range for Sato is 1.0" wide x ¼" long minimum to 6.5" wide x 10" long maximum, for Zebra is 5/8" wide x ½" long minimum to 7.1" wide x 10" long maximum, for Datamax is 1.0" wide x ¼" long minimum to 6.64" wide by 10" long maximum.

NOTE: Sizes depend on print engine model, contact CTM Labeling Systems for custom sizes and shapes.

Print Resolution and Speed are 203 dpi, 305 dpi, 600 dpi with print speeds programmable up to 16"/sec, dpi dependent. Print capabilities include fonts of various sizes and styles with independent height and width expansion; includes OCR A/B.

Bar Codes include EAN 8/13, Code 39, Code 93, UPC A/E (with extensions), Code 128, I 2 of 5, Maxicode, DataMatrix, PDF417, MicroPDF, CODABAR, MSI, and POSTNET.

The Graphics feature supports user defined fonts and graphics including custom logos. Labeling speed is dependant upon label size, print speed, cylinder stroke and application type.

Standard machine features heavy duty construction for both Tamp Blow and All Electric Tamp, external valves (Tamp Blow unit only - All Electric Tamp does not require valve bank), operator keypad & display, 12" O.D. label roll, i/o connection and communication port connections.

Operator Interface

The 6", 256 color, TFT touch screen provides bold, bright, high contrast display with self-diagnostic platforms and multi-level intuitive set-up features, offering quick access to set-up selection for application operating parameters.

Optional Features

Variable height sensing

Low label/low ribbon

Out of label/out of ribbon

Red, amber, green "ready" light stack

16" unwind for large label rolls

Dimensions

33" L x 27.25" W x 43.5" H

Weight

Approx. 195 lbs.

Electrical

108-132 Volts AC, 7 Amps, 50/60 Hertz, Single Phase

Pneumatic

90-100 psi., 4 CFM

Communications

RS 232, Parallel, Ethernet, others available

Environmental

Operating: 41° to 104° F (5° to 40° C)

Storage: -4° to 104° F (-20° to 40° C)

Printing Methods

Thermal Transfer & Direct Thermal

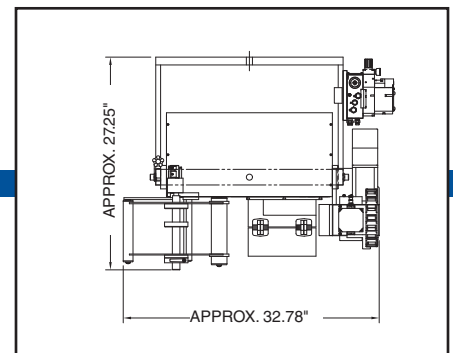
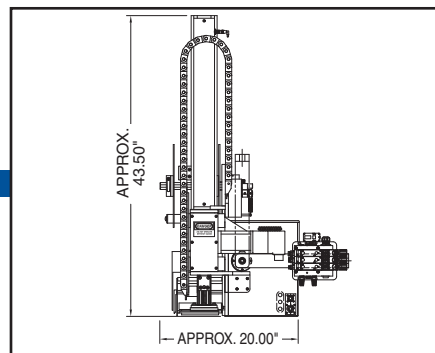
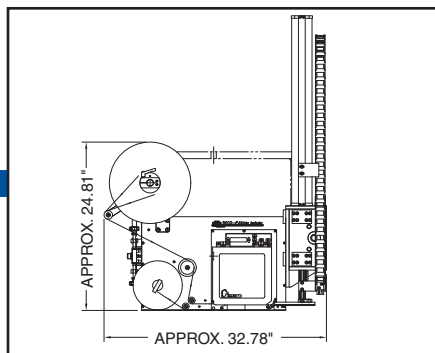
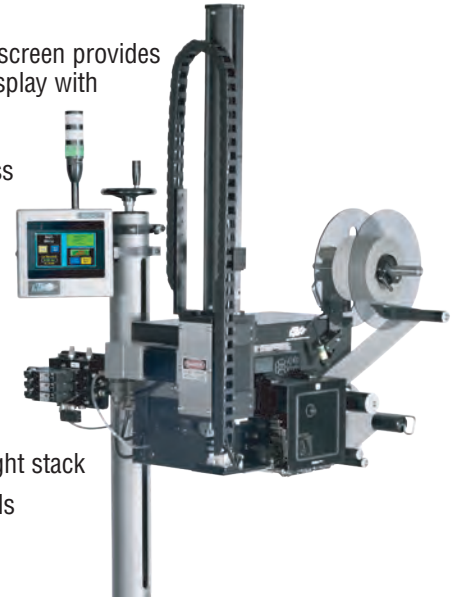

Distributed By:



1421 W. Main Street
Alliance, Ohio 44601
330-938-2134

www.mpilabels.com



1318 Quaker Circle
P.O. Box 589
Salem, Ohio 44460
(330) 332-1800



www.ctmlabelingsystems.com